



US005727554A

United States Patent [19]

[11] Patent Number: 5,727,554

Kalend et al.

[45] Date of Patent: Mar. 17, 1998

[54] APPARATUS RESPONSIVE TO MOVEMENT OF A PATIENT DURING TREATMENT/DIAGNOSIS

[75] Inventors: Andre M. Kalend, Monroeville; Joel Greenberger, Sewickley; Karun B. Shimoga, Pittsburgh; Charalambos N. Athanassiou, Pittsburgh; Takeo Kanade, Pittsburgh, all of Pa.

[73] Assignee: University of Pittsburgh of the Commonwealth System of Higher Education, Pittsburgh, Pa.

[21] Appl. No.: 715,834

[22] Filed: Sep. 19, 1996

[51] Int. Cl.⁶ A61B 6/00

[52] U.S. Cl. 128/653.1

[58] Field of Search 128/630, 653.1, 128/660.03; 364/413.02, 413.13, 413.25, 413.26; 356/375; 378/69, 205

[56] References Cited

U.S. PATENT DOCUMENTS

4,466,075	8/1984	Groch et al.	364/413.26 X
5,080,100	1/1992	Trotel	128/653.1
5,103,823	4/1992	Acharya et al.	128/653.1
5,214,711	5/1993	Neely et al.	364/413.27 X
5,295,483	3/1994	Nowacki et al.	128/660.03
5,389,101	2/1995	Heilbrun et al.	128/653.1 X
5,398,684	3/1995	Hardy	128/653.1
5,446,548	8/1995	Gerig et al.	128/653.1 X
5,482,042	1/1996	Fujita	128/653.1
5,558,430	9/1996	Bova et al.	128/653.1

OTHER PUBLICATIONS

Active Shape Models—'Smart Snakes', T.F. Cootes and C.J. Taylor, pp. 267-275, Proceedings of European Conference on Computer Vision, Genoa, Italy, 1992.

Training Models of Shape from Sets of Examples, T.F. Cootes, C.J. Taylor, D.H. Cooper, and J. Graham, pp. 8-18, Proceedings of European Conference on Computer Vision, Genoa, Italy, 1992.

A Computational Framework and an Algorithm for the Measurement of Visual Motion, P. Anandan, pp. 283-310, International Journal of Computer Vision, 2, 1989.

Feature Extraction from Faces Using Deformable Templates, A.L. Yuille, P.W. Hallinan, and D.S. Cohen, pp. 99-111, International Journal of Computer Vision, 8:2, 1992.

Computer and Robot Vision, vol. I R. M. Haralick and L. G. Shapiro, pp. 328-353, Library of Congress Cataloging-in-Publication Data, 1992.

Motion Tracking with an Active Camera, D. Murray and A. Basu, pp. 449-459, IEEE Transactions on Pattern Analysis and Machine Intelligence, vol. 16, No. 5, May 1994.

Primary Examiner—Francis Jaworski

Attorney, Agent, or Firm—Richard V. Westerhoff; Eckert Seamans Cherin & Mellott, LLC

[57] ABSTRACT

A camera generates digital image signals representing an image of one or more natural or artificial fiducials on a patient positioned on treatment or diagnosis equipment. A processor applies multiple levels of filtering at multiple levels of resolution to repetitively determine successive fiducial positions. A warning signal is generated if movement exceeds certain limits but is still acceptable for treatment. Unacceptable displacement results in termination of the treatment beam. Tracking templates can be generated interactively from a display of the digital image signals or through automatic selection of an image having the median correlation to an initial template. A gating signal synchronized to patient breathing can be extracted from the digital image signals for controlling the radiation beam generator.

22 Claims, 12 Drawing Sheets

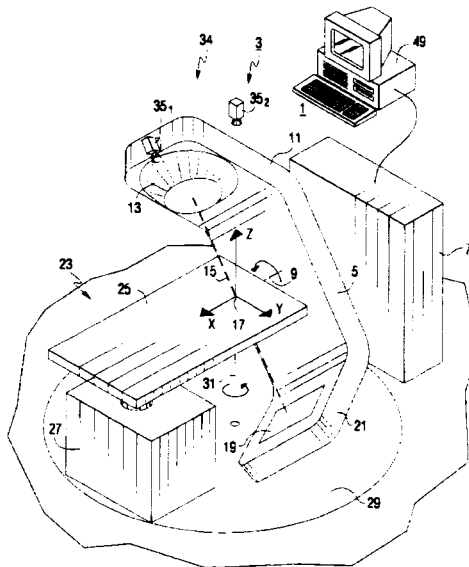

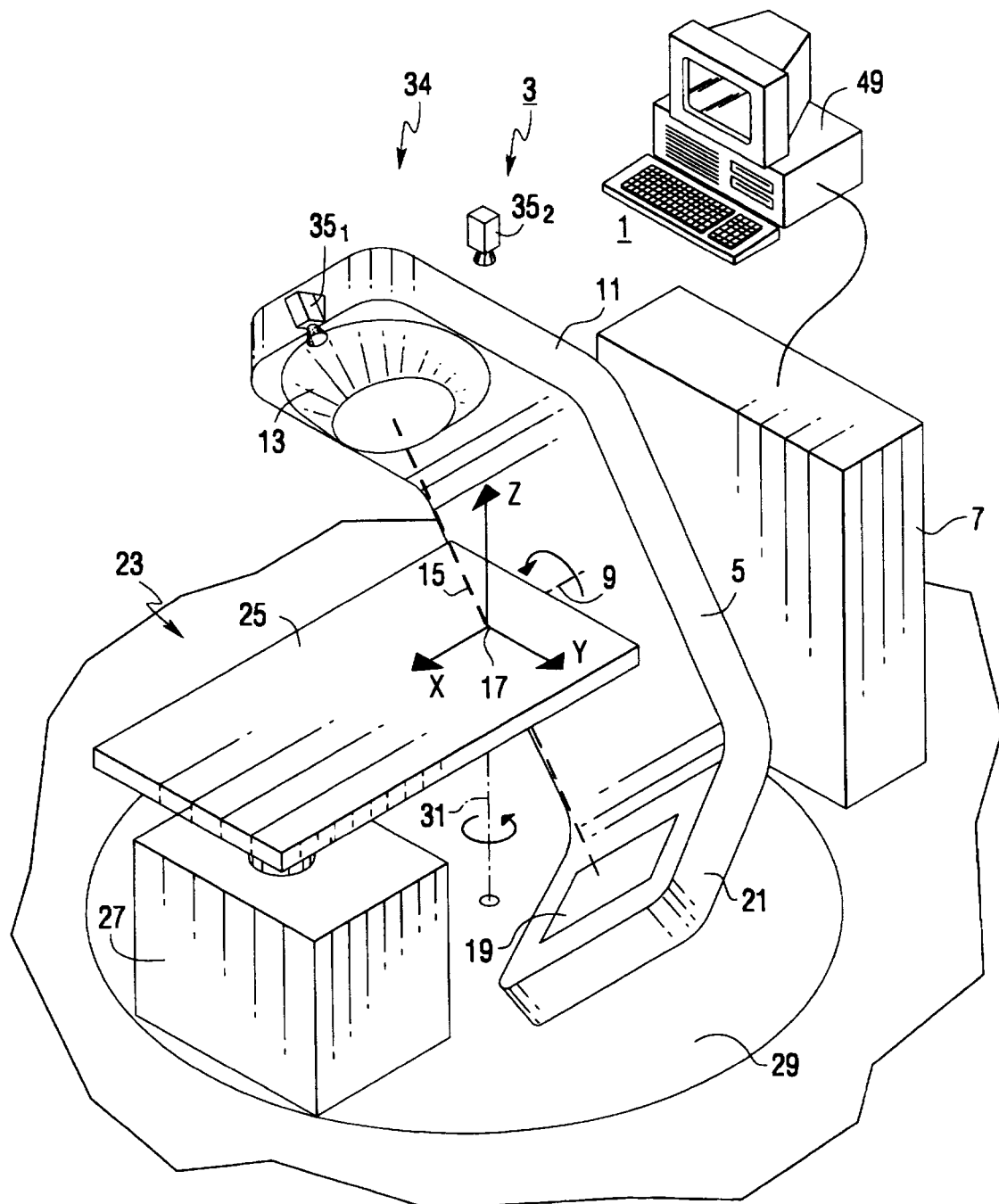

FIG. 1

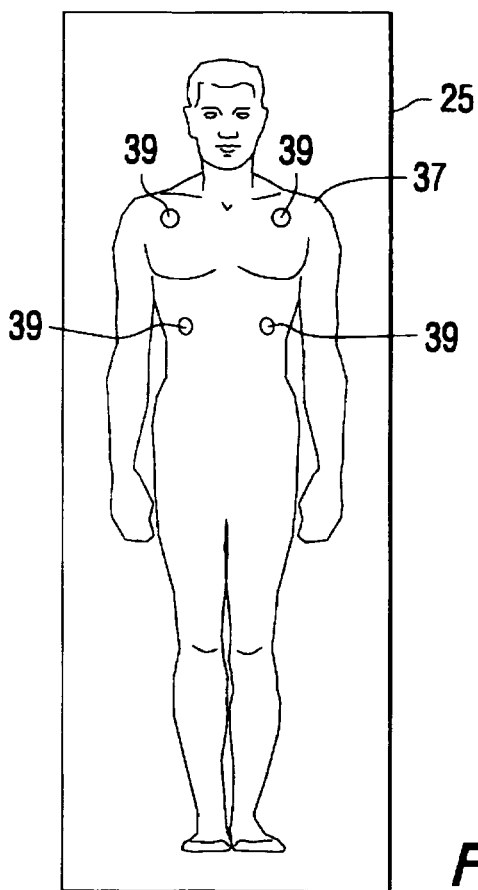

FIG. 2

PERFORM BRACKETING
ON SELECTED POINT/MATCHES
IN HI-RES IMAGE

115.1

115

FILTER SECONDARY
MATCHES/POINTS WITHIN THE
SAME IMAGE NEIGHBORHOOD
USING MIN-SUPPRESSION

115.2

GO TO BLOCK 116

FIG. 9

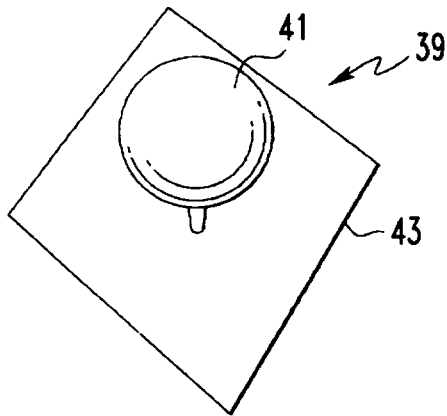

FIG. 3

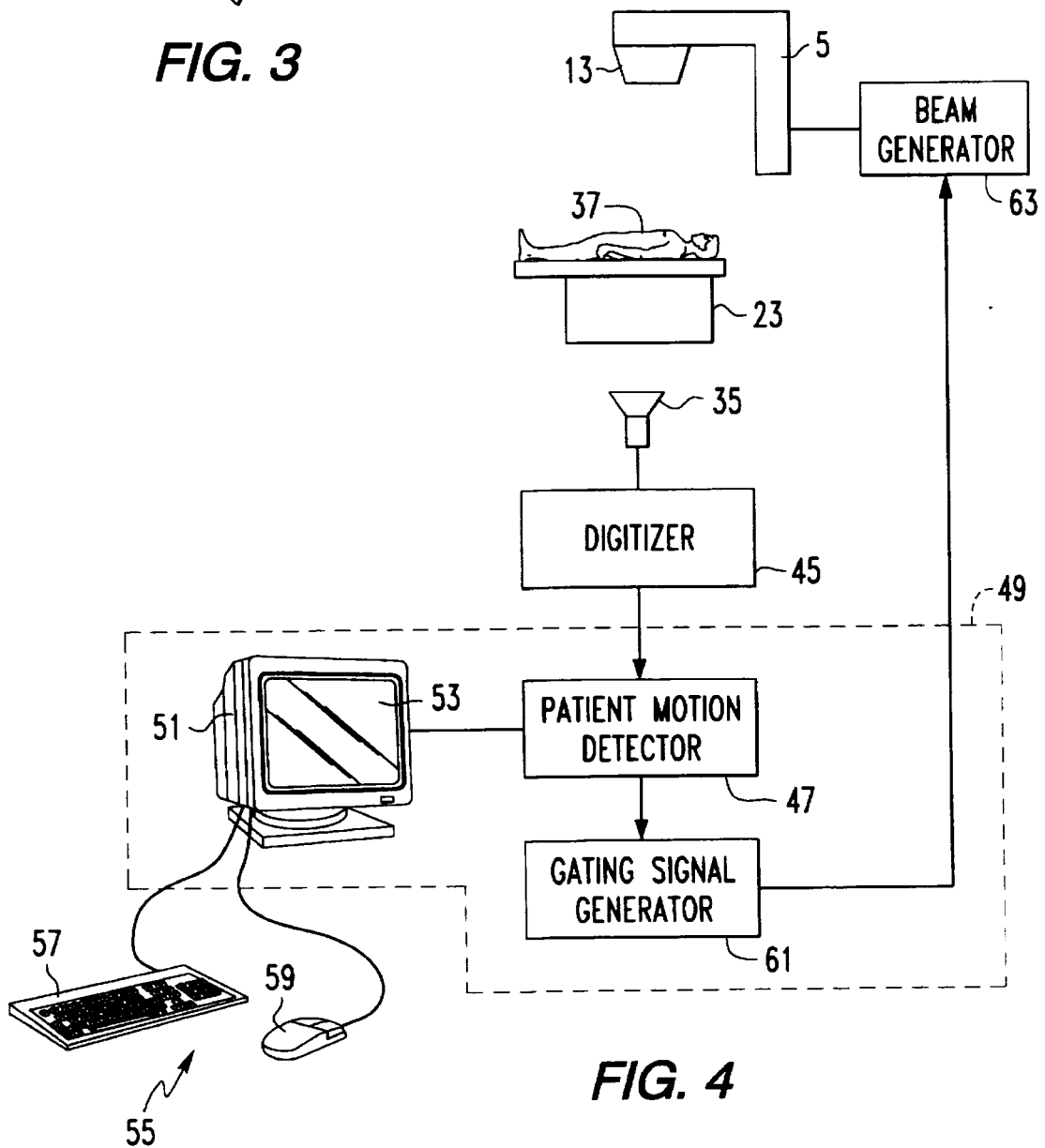

FIG. 4

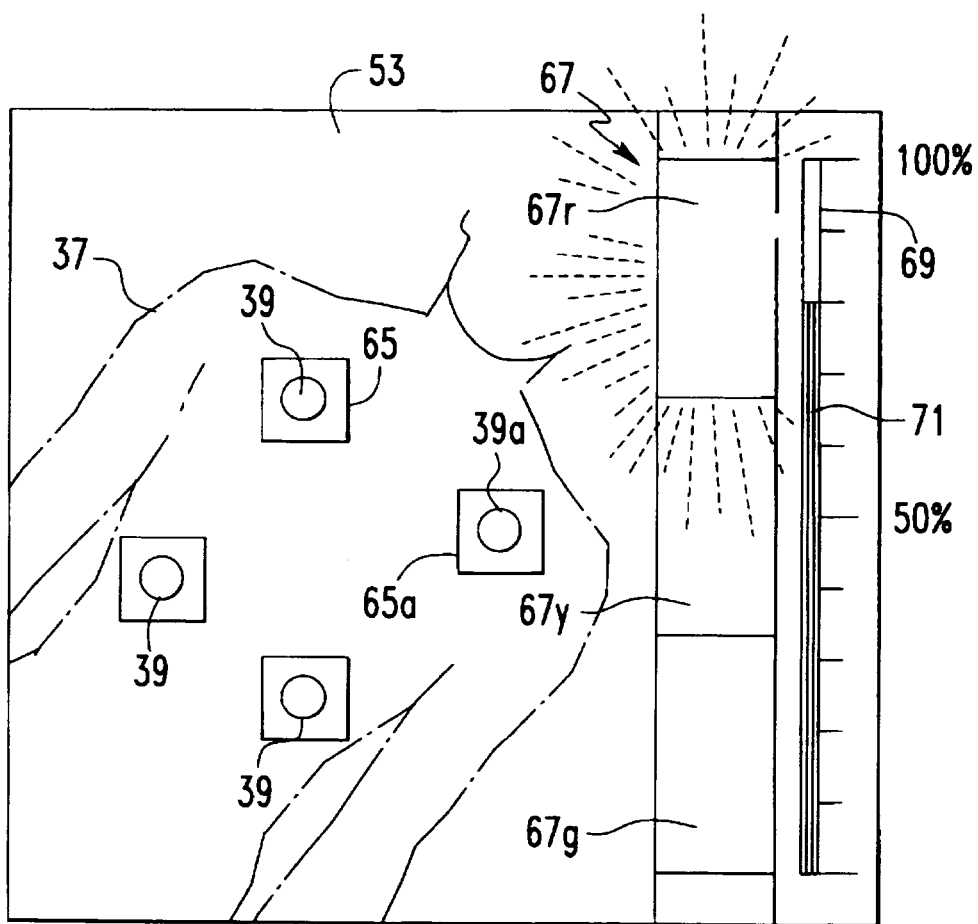

FIG. 5

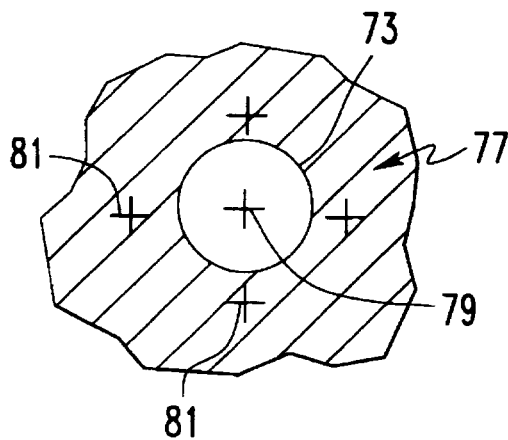

FIG. 17

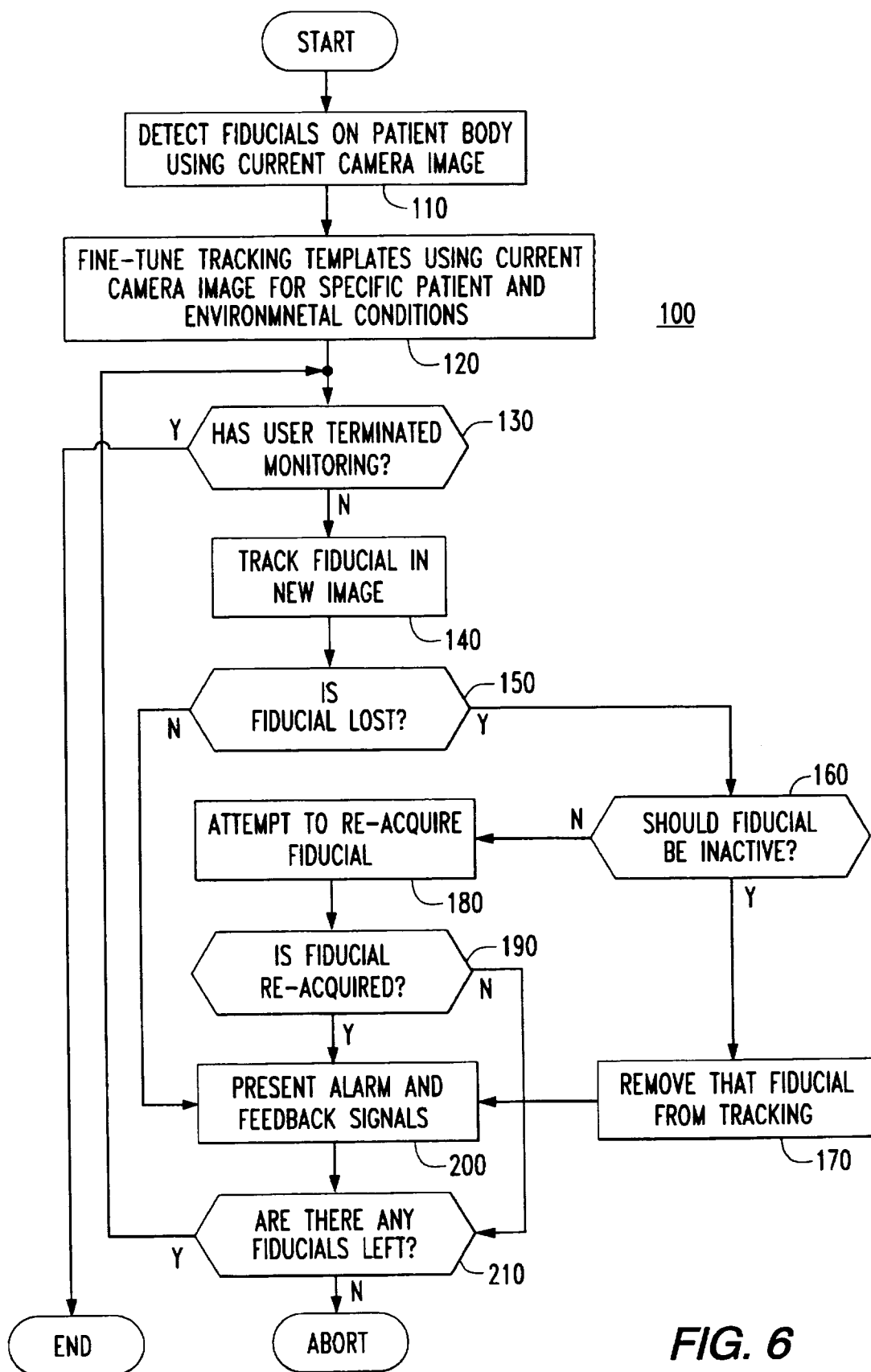

FIG. 6

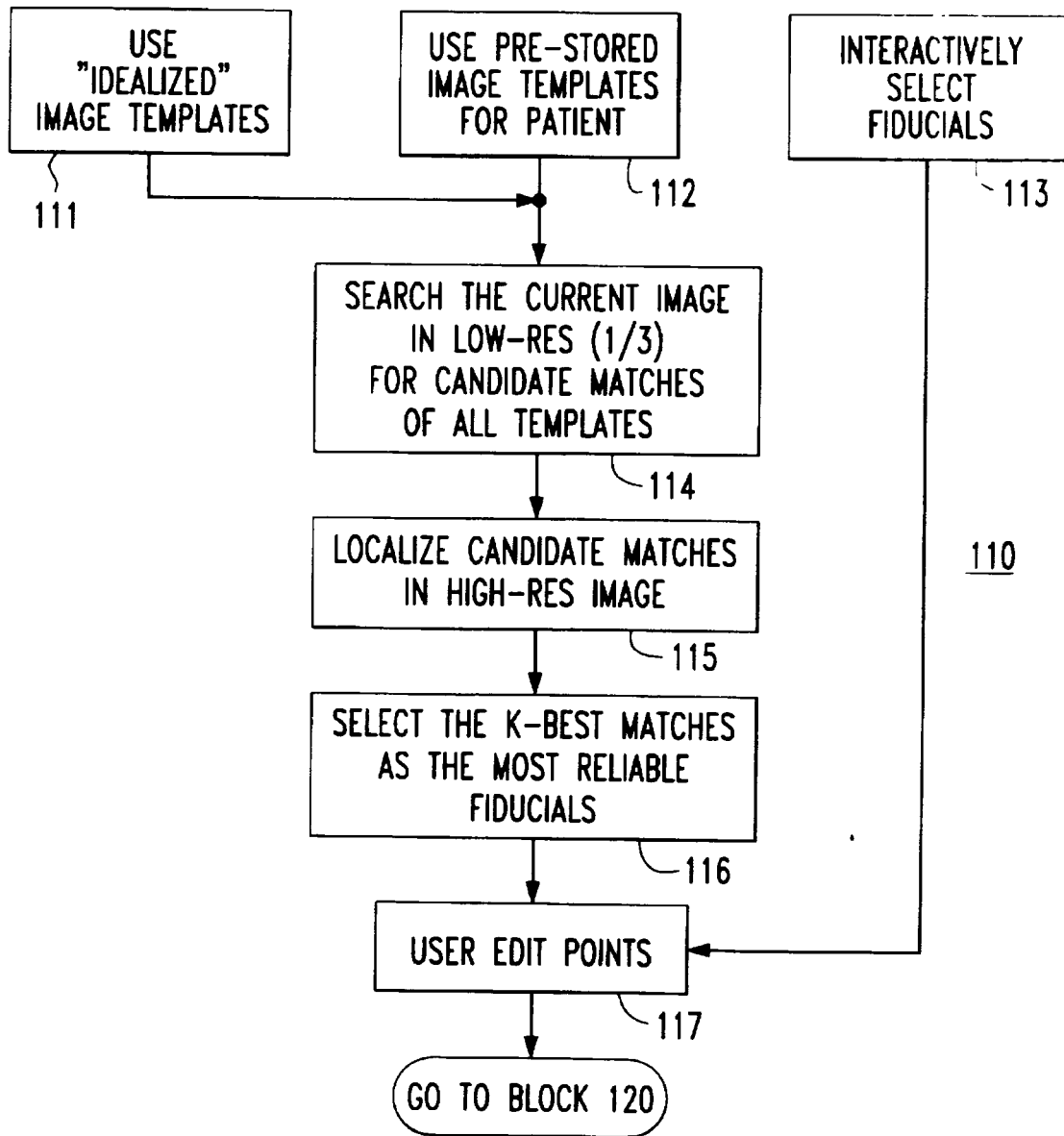

FIG. 7

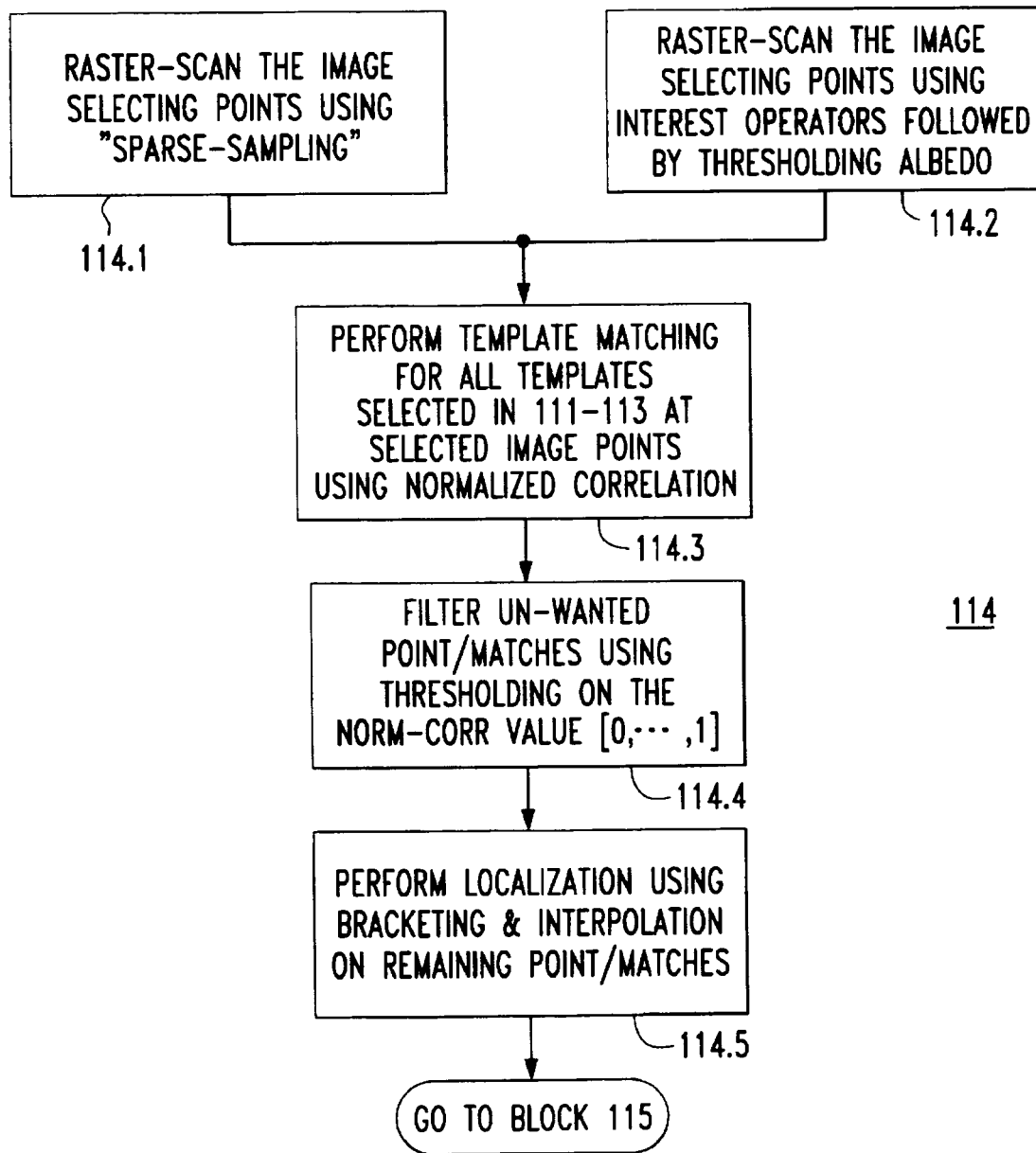

FIG. 8

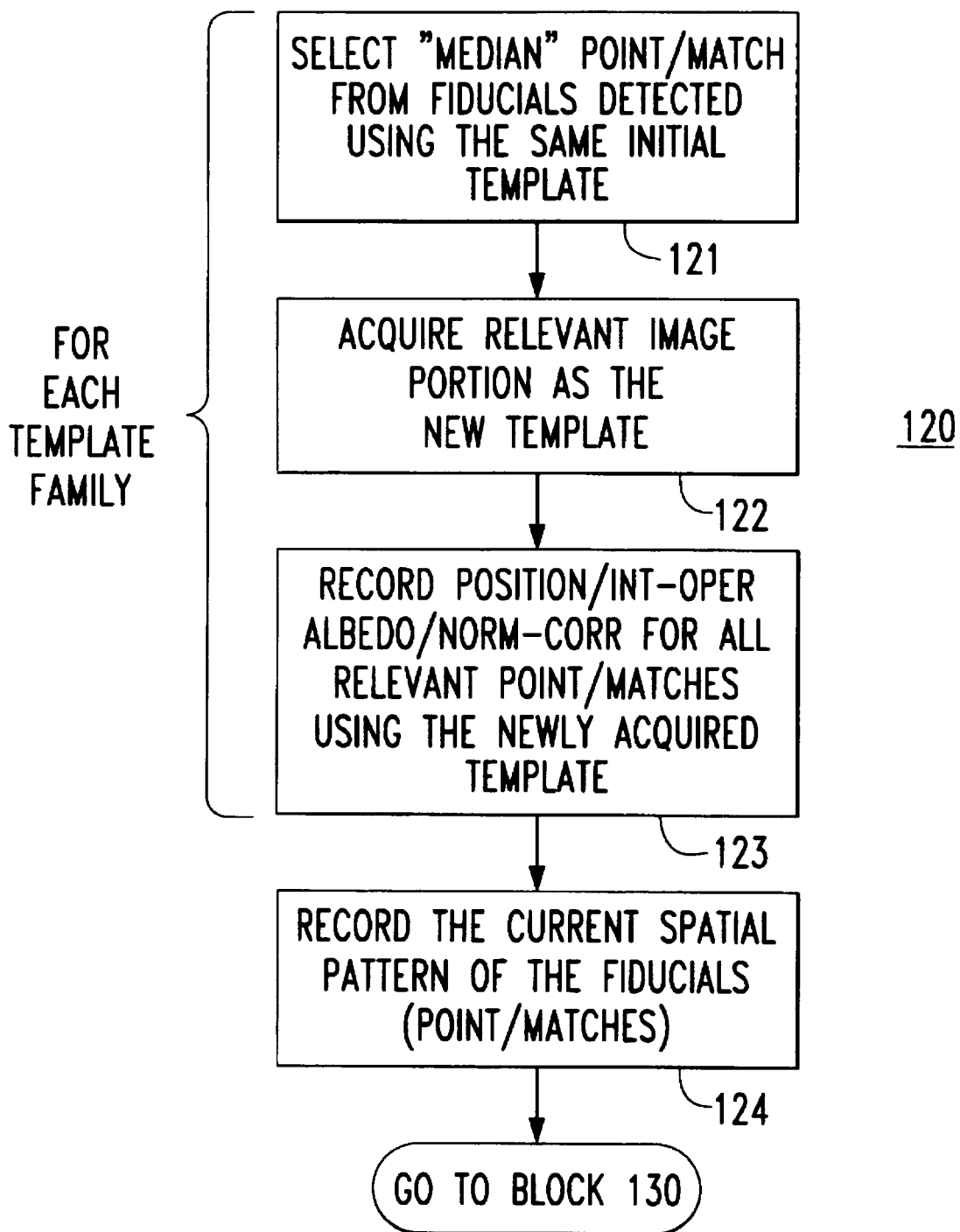

FIG. 10

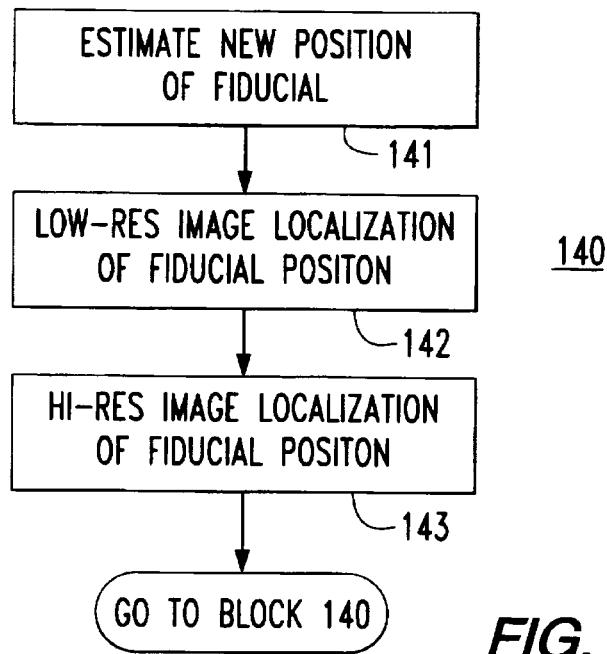

FIG. 11

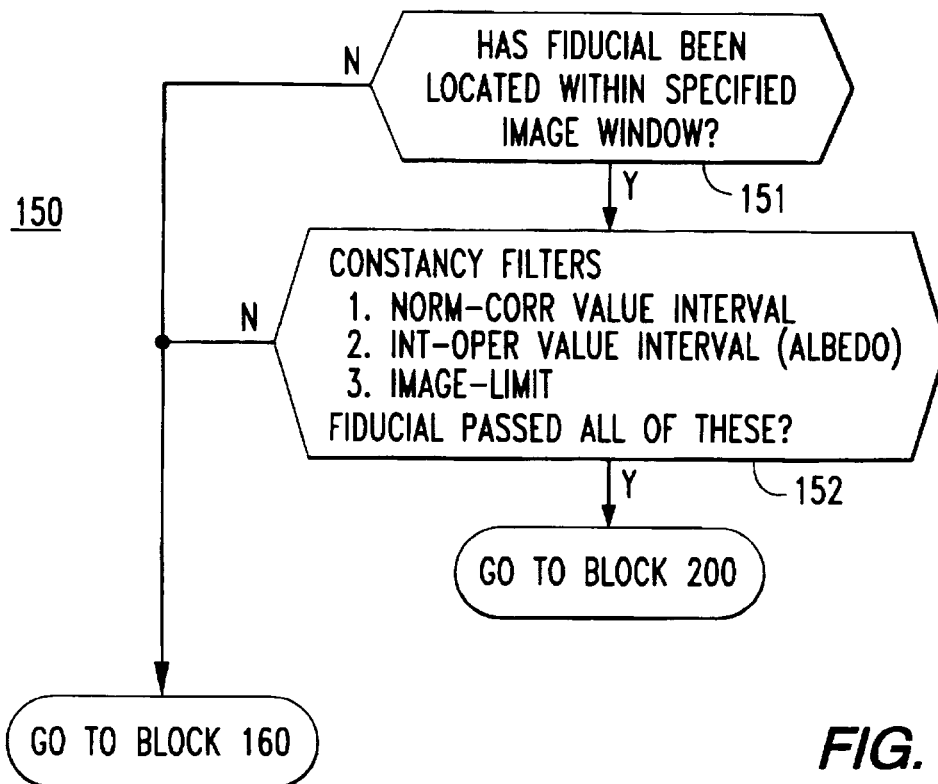

FIG. 14

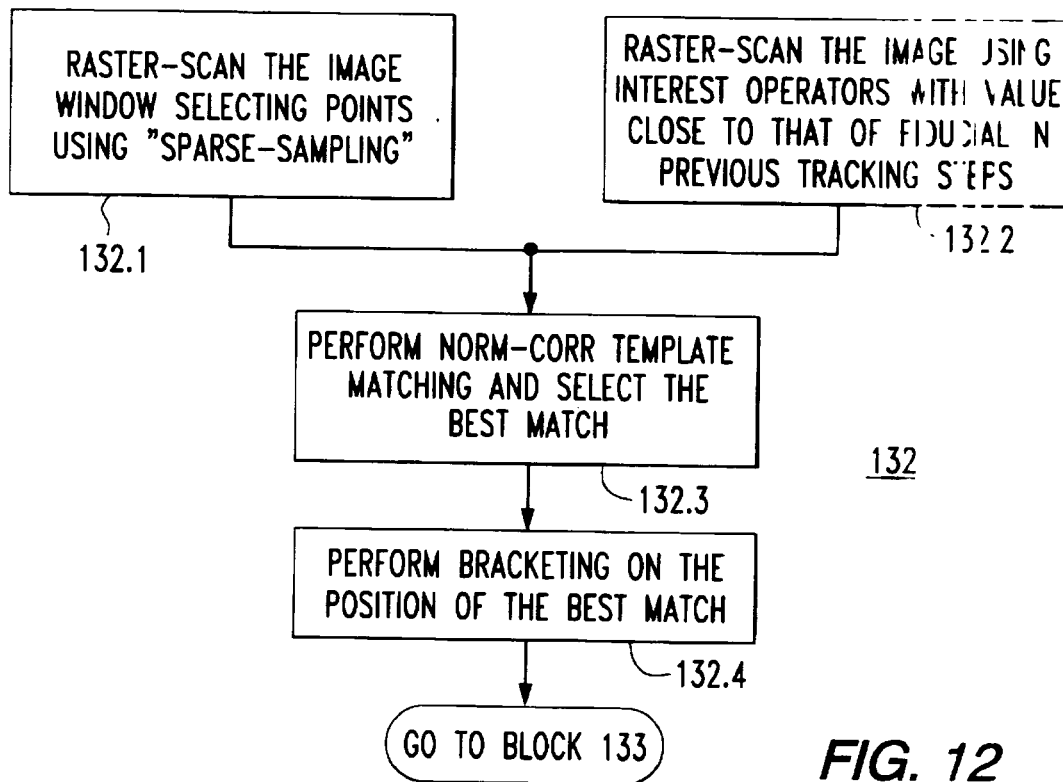

FIG. 12

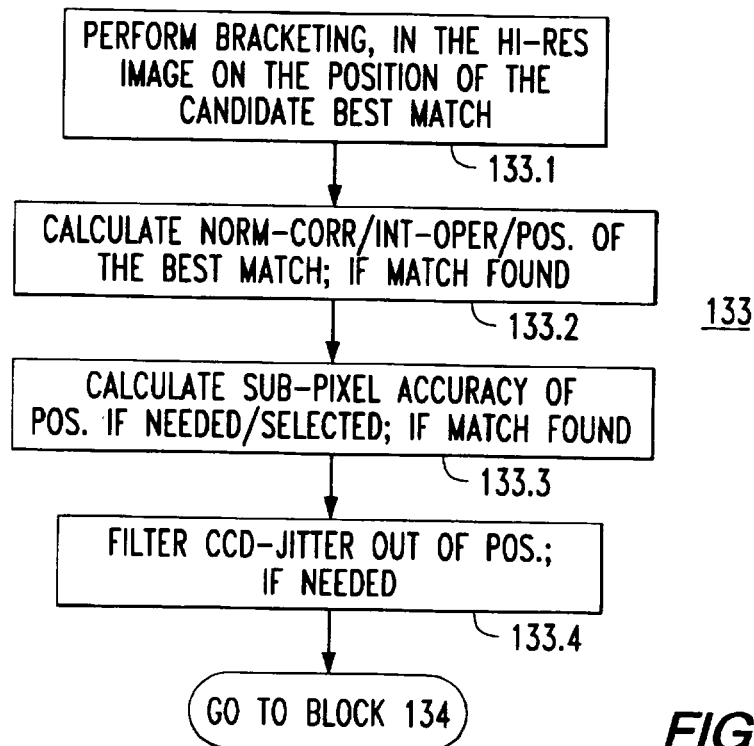

FIG. 13

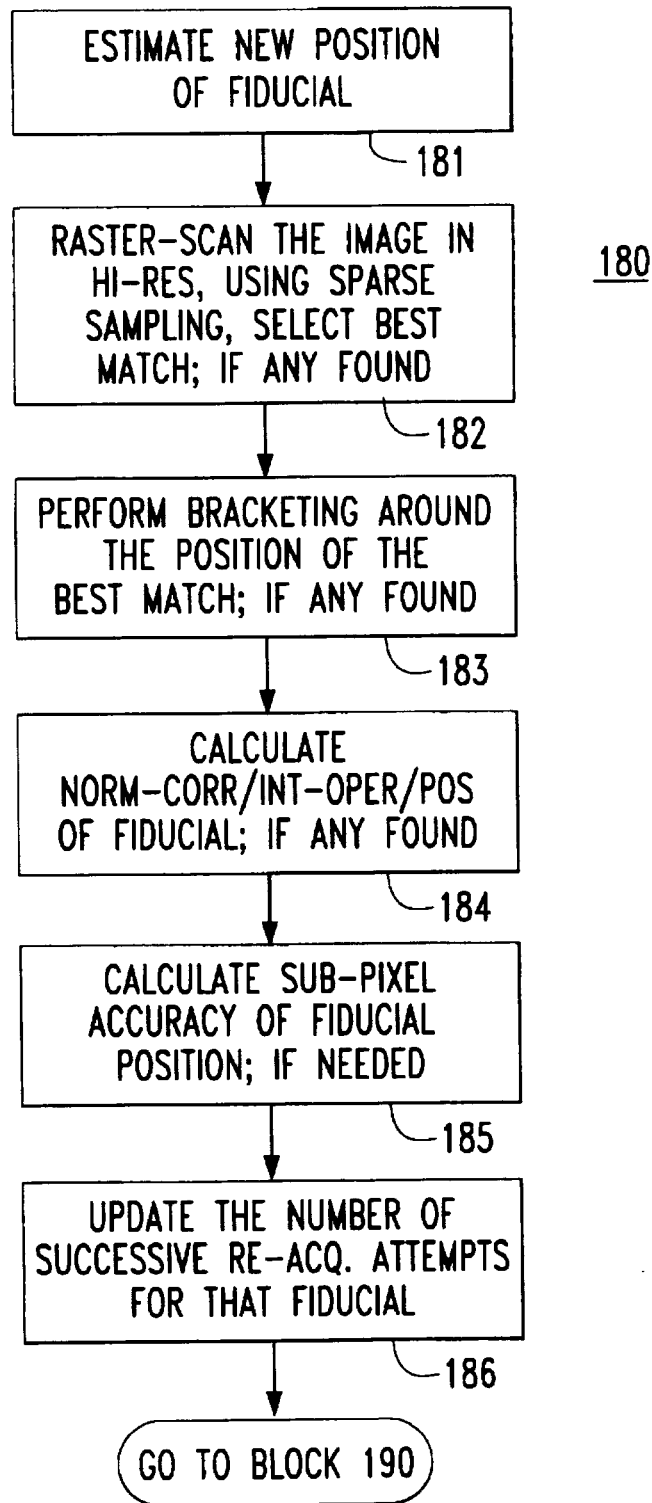

FIG. 15

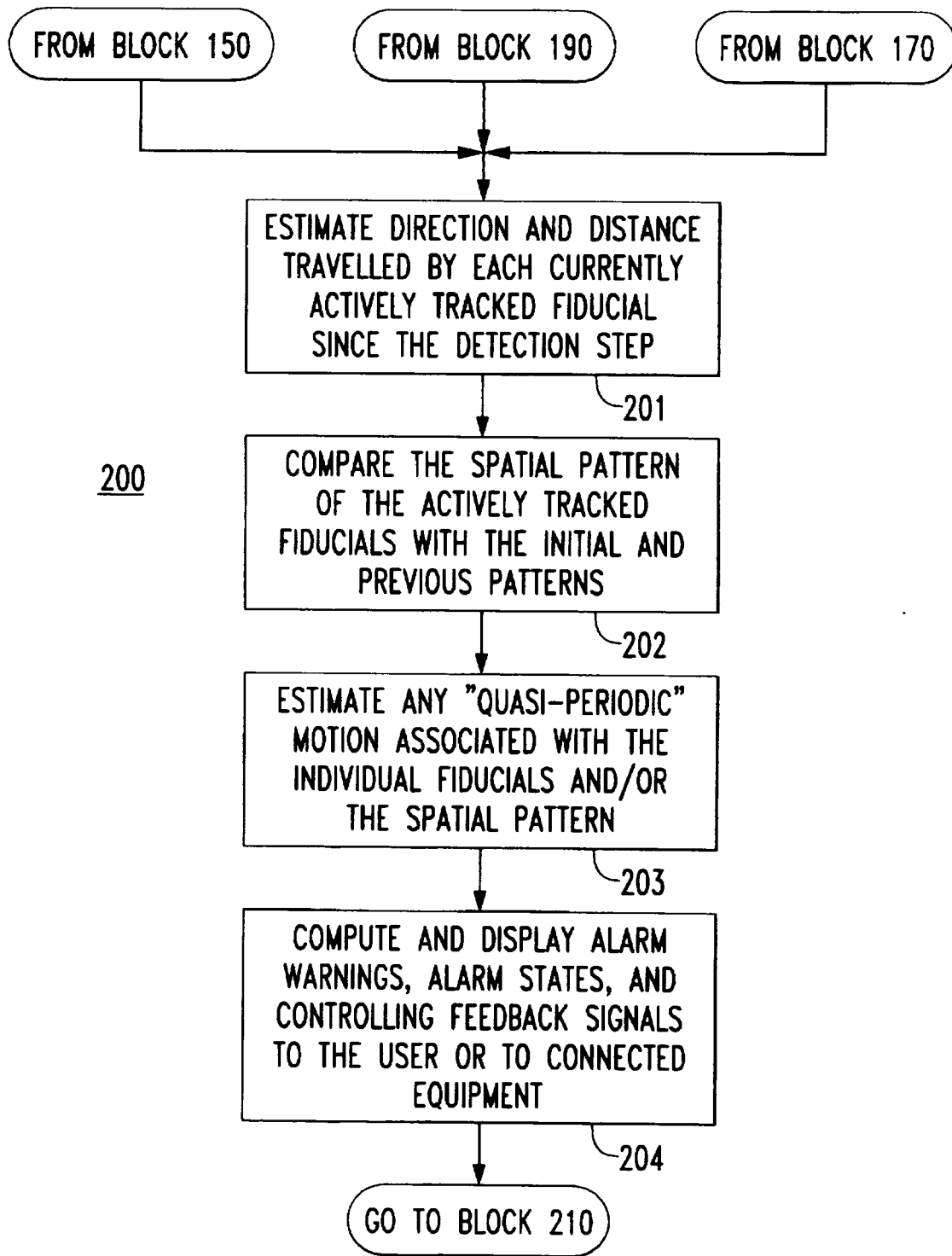

FIG. 16

1

APPARATUS RESPONSIVE TO MOVEMENT OF A PATIENT DURING TREATMENT/ DIAGNOSIS

BACKGROUND OF THE INVENTION

1. Field of the Invention

This invention relates to medical use of radiation for treatment and diagnosis, and more particularly to detection and response to patient movement during radiological treatment and diagnosis.

2. Background Information

Conventional radiotherapy treatment relies on simple patient setup techniques. These techniques use stationary and a limited number of radiation fields, which are often much wider than the tumor or volume, thus effectively compensating for the possibility of a tumor geometric miss. Consequently, a substantial amount of healthy tissue is irradiated and becomes a radio-biological dose limiting factor in tumor control.

Modern conformal dynamic radiotherapy attempts to overcome the above radio-biological limitation by tight-margin conformation of radiation dose distribution tailored to the three-dimensional tumor volume by the use of computer-control multibeam conformal dynamic radiotherapy (CCRT). Consequently, the accuracy in patient position, knowledge of the movement of a patient including substantial motion of internal organs such as with breathing is of primary importance. In addition to patient movement which would cause the tight beam to miss the tumor, it is important to be able to detect patient movement which could cause a collision between the patient and the linear accelerator, which is repeatedly repositioned to establish the multiple treatment beams.

There is a need therefore for apparatus for detecting patient movement on radiological treatments/diagnostic equipment.

There is a particular need for such apparatus which can detect submillimeter patient movement in real time.

There is also a need for such apparatus which can detect patient movement initiated from various treatment positions.

There is also a need for such apparatus which can detect patient movement under varying lighting conditions.

There is a further need for such apparatus which can discriminate movement associated with patient breathing from other movement and accommodate therefor.

SUMMARY OF THE INVENTION

These needs and others are satisfied by the invention which is directed to apparatus responsive to movement of a patient which identifies and tracks movement of at least one passive fiducial on the patient. The apparatus applies multiple levels of filtering which can include: correlation, preferably normalized correlation, sparse sampling, bracketing and interpolation, and minima suppression to rapidly identify the location of the at least one fiducial. The multiple levels of filtering are applied at multiple levels of resolution of the digital image signals.

Interest operators can be used in combination with templates to locate the positions of the passive fiducials. The templates can be selected interactively by a user from a display generated by the digital image signals. Alternatively, the template used for tracking is selected from images generated using an initial template. Rather than using the image which best matches the initial template, the template with a median match is selected.

2

As another aspect of the invention, the means generating an output includes means indicating movement of the at least one passive fiducial relative to at least one selected level of displacement. Preferably, the output means generates a warning that movement exceeds a first displacement and includes means providing a signal for terminating radiation treatment when the movement exceeds a second greater displacement. Preferably, the means providing an indication of movement includes a display generating an image of the patient and the fiducials, together with an indication of movement relative to the first and second displacements.

As yet another aspect of the invention, the means determining movement of the passive fiducials includes means detecting movement associated with patient breathing and random movement. The movement associated with patient breathing can be used to generate a gating signal synchronized to patient breathing. This gating signal can then be used to actuate the beam generator only during selected parts of the breathing cycle.

BRIEF DESCRIPTION OF THE DRAWINGS

A full understanding of the invention can be gained from the following description of the preferred embodiments when read in conjunction with the accompanying drawings in which:

FIG. 1 is an isometric view of apparatus in accordance with the invention for implementing conformal dynamic radiotherapy.

FIG. 2 is a plan view of a patient reclining on a couch which forms part of the apparatus of FIG. 1 and illustrating the placement of fiducials in accordance with the invention.

FIG. 3 is a perspective view of a preferred fiducial used in implementation of the invention.

FIG. 4 is a functional diagram illustrating implementation of the invention.

FIG. 5 is an illustration of a display which is generated by the apparatus of FIG. 1 in implementation of the invention.

FIGS. 6-16 are flow charts of software used in implementation of the invention.

FIG. 17 is an illustration of an interest operator which can be used in implementation of the invention.

DESCRIPTION OF THE PREFERRED EMBODIMENT

FIG. 1 illustrates a radiotherapy treatment system 1 in which the invention is implemented. This system 1 includes a machine 3 having a gantry 5 pivotally mounted on a machine base 7 for rotation about a horizontal axis 9. The gantry 5 has a first arm 11 carrying a collimator 13 which directs a beam of high energy radiation 15, such as a beam of high energy photons, along a path which is perpendicular to and passes through an extension of the axis of rotation 9. This intersection is referred to as the isocenter 17. In some machines, a portal imager 19 is mounted on a second arm 21 on the opposite end of the gantry in alignment with the radiation beam 15. The portal imager 19 records radiation which is not absorbed by the patient.

The isocenter 17 serves as the origin of a coordinate system for room space. As can be seen, the X axis coincides with the axis of rotation 9 of the gantry. Thus, as the gantry 5 rotates it defines a plane of treatment containing the Y and Z axes.

The machine 3 further includes a patient positioning assembly 23, which includes a couch 25 mounted on a

support 27 for vertical, lateral and longitudinal movement relative to the support. The support 27 is mounted on a turntable 29, which has its axis 31 vertically aligned under the isocenter 17 and concentric with the Z axis. With this arrangement, the patient positioning assembly 23 has four degrees of freedom: translation in the X, Y and Z axes of room space and rotation about the Z axis. Thus, the patient is not rotated about the longitudinal axis of the couch or tilted about a horizontal axis extending transversely through the couch. However, with the addition of rotation of the gantry in the Y-Z treatment plane, the radiation beam 15 can be directed through a patient reclining on the couch 25 in any desired direction. A computer 33 controls movement of the patient positioning assembly 23 and the gantry 5 for establishing the progression of high energy treatment beams used in practicing conformal radiation therapy.

As previously discussed, in conformal radiation therapy the beam 15 is tightly conformed by the collimator 13 to the specific tumor to be treated. Thus, movement of the patient on the couch 25 of the patient position assembly 23 can cause misalignment of the radiation beam 15 with the tumor. This not only degrades treatment of the tumor but also exposes surrounding healthy tissue to unwanted levels of radiation. In addition, normal breathing by the patient can cause movement of internal organs by an amount which would result in misalignment of the beam. For instance, a tumor on the lower portion of the lung can move several centimeters during normal breathing. Slight movement of the patient can be tolerated; however, treatment should be terminated if acceptable tolerances of movement are exceeded. Furthermore, excessive movement by the patient can also cause a collision between the patient and the gantry as the patient positioning assembly 23 and gantry are positioned for successive treatment beams.

The invention employs a vision system 34 to measure and respond to patient movement. The vision system 34 includes at least one video camera 35. Preferably, multiple cameras are used. In the exemplary embodiment of the invention a first camera 35₁ is mounted on the first arm 11 of the gantry 5 adjacent the collimator 13 and is aimed to capture an image of a patient 37 positioned on the couch 25, as shown in FIG. 2. As the camera 35₁ will be below the couch 25 for some positions of the gantry 5, a second camera 35₂ is fixed to the ceiling over the patient positioning assembly 23. The field of view of this camera 35₂ will be blocked when the gantry 5 is at the top of its arc. Thus, the patient is visible to at least one camera 35 at all times. Additional cameras 35 could be provided, such as cameras laterally displaced from the patient positioning assembly 23 to provide more sensitivity to movement along the axis of, for instance, the camera 35₂. However, as will be discussed below, a single camera can detect three-dimensional movement, including movement toward and away from the camera which is detected as a change in the size of the image.

In the exemplary embodiment of the invention, natural or artificial fiducials are used to detect patient movement. Natural fiducials could be scars or other prominent features of the patient. The preferred fiducial 39 shown in FIG. 3 is a sphere 41 covered with a material having a lambertian surface. Such a surface is highly reflective under low light conditions, yet provides a uniform scattered reflection with no highlights. The sphere 41 is attached to the center of a non-reflective base 43 which is secured to the patient's skin, such as by an adhesive.

In principle, only one fiducial 39 is required. As a practical matter, it is advantageous to provide multiple fiducials placed on the patient so as to detect any movement of the

critical locations. Thus, as shown in FIG. 2, by way of example, four fiducials 39 are placed on the patient's chest. Natural skin markings could be used in addition to the artificial fiducials shown in FIG. 3. If more than one camera 35 is used, each tracks as many of the fiducials 39 as it can see.

FIG. 4 is a functional diagram of the invention. The camera(s) 35 capture an image of the fiducials 39 on the patient 37 reclining on the patient positioning assembly 23. The image captured by the camera 35 is digitized by digitizer 45 to generate digital image signals. These digital image signals are 0 to 255 gray scale signals for each camera pixel. The digital image signals are processed by a processor which includes a patient motion detector 47. Patient motion detector 47 is implemented in the computer 49 shown in FIG. 1. The computer 49 includes a monitor 51 which generates a display 53, an example of which is shown in FIG. 5. The man machine interface 55 for the computer 49 includes a keyboard 57 and a pointing device 59, such as a mouse or trackball.

As will be discussed fully, the patient motion detector 47 detects and identifies the fiducials 39 and then tracks their movement. Movement within a certain narrow tolerance is acceptable, while larger movements are unacceptable. Visible and/or audio warnings of these two classifications of movement can be generated. A gating signal generator 61 responds to unacceptable movement to disable the beam generator 63. This unacceptable movement which would terminate the radiation beam can be movement which displaces the target tumor so that it is missed by the radiation beam, or could be movement which would cause a collision between the patient and the gantry 5 during movement of the machine from one treatment beam to the next. In the former case, the gating signal generator 61 could re-enable the beam generator, if the patient returns to the proper position. For instance, a large sigh could temporarily displace the target area by an unacceptable amount. In accordance with another aspect of the invention, the patient motion detector 47 can track patient breathing and extract such quasi-periodic motion from random patient motion. Gating of the beam generator can then be synchronized with patient breathing. For instance, a tumor on the lung could move up to 4 to 5 centimeters during patient breathing. This is an unacceptable amount of movement. However, by synchronizing generation of the radiation beam with breathing, the tumor can be repetitively irradiated at a fixed position during the breathing cycle.

As shown in FIG. 5, the display 53 presents an image of the patient 37 with the fiducials 39 appearing prominently. An indicator 65, such as the square shown, surrounds each fiducial and is color coded to indicate the state of motion of the fiducial. The fiducial with the largest displacement such as 39a is singled out by a distinctive marker, such as a red square 65a, while the remaining markers are green squares in the exemplary system. The display also includes a traffic light 67 having a green section 67g, a yellow section 67y and a red section 67r. When motion of the fiducials is within preferred tolerances, the green section 67g of the traffic light is on. For motion which is outside the normal range, but which is still acceptable, the yellow section 67y is on. The traffic light turns red when the motion of any of the fiducials is approaching the unacceptable. A scale 69 along the side of the display 53 indicates in bar graph form the percentage of maximum allowable displacement of the fiducial of maximum displacement. Thus, for instance, if the red light 67r is illuminated and the bar graph 71 indicates 80%, the fiducial with maximum displacement has moved by a distance which

5

is four fifths of the way through the acceptable displacement. The green, yellow and red regions need not be equal as shown in the example.

Detection of motion of a patient using passive fiducials requires an implementation which is robust enough to accommodate for the variations in the shapes, appearance and lighting conditions to which the fiducials are subjected and, at the same time, is fast enough to provide real time tracking of patient movement. The invention satisfies these requirements by utilization of successive levels of filtering and templates which are modified to accommodate for actual conditions. The result is a system which can track patient movement at 20 Hz or better.

Flow charts of suitable software 100 for implementing the invention are illustrated in FIGS. 6-16. FIG. 6 illustrates the main routine of the software 100 and includes detecting fiducials on the patient's body in the current camera image at 110. As will be described, this is accomplished utilizing templates. The templates are then fine tuned at 120 for the specific patient and environmental conditions. As long as the user desires monitoring as determined at 130, a loop is entered in which each individual fiducial is tracked as indicated at 140. It is possible that a fiducial can be lost by the tracking system. This could occur, for instance, if the patient moves so that a fiducial is blocked from the camera's view, or the patient moves a hand through the line of sight of the camera. Also, a fiducial may be temporarily lost by rapid movement or adverse lighting conditions. If a fiducial is lost, as determined at 150, a number of attempts can be made to reacquire it. If the fiducial is not reacquired within a reasonable time, however, it is removed from tracking as indicated by 160 and 170. If the selected number of attempts to reacquire, such as for example, five, have not been reached, an attempt is made to reacquire the fiducial at 180. If the fiducial is reacquired at 190, then a routine is run at 200 to generate any alarm if needed, and gating signals for the accelerator or beam generator 63 as indicated at 200. As long as any fiducials remain to be tracked as indicated at 210, the tracking loop is repetitively run.

FIG. 7 illustrates the general routine 110 for detecting the fiducials 39 in the image represented by the digital image signals. As mentioned, templates are used to identify the locations of the fiducials. The templates indicate what the pattern of digital signals representing the fiducial should look like. The size of the templates used must be considered. Larger templates improve the accuracy but take longer to process. In the exemplary system, templates 40 pixels square have been utilized. There are several ways in which the templates can be generated. As indicated at 111 in FIG. 7, idealized image templates can be utilized. In addition to such idealized templates or in place thereof, pre-stored image templates for the patient can be used as indicated at 112. Such pre-stored templates are used, for instance, for natural fiducials such as scars. One template is used for each family of fiducials. For instance, if all of the fiducials are the preferred fiducials such as shown in FIG. 3, only one template is required because all of the fiducials in the family will generate a similar image.

In addition, templates can be selected interactively by the user at 113. This is accomplished by using the mouse or trackball 59 to click on the center of a representation of the fiducial on the display 53.

Where the idealized or pre-stored templates are utilized, a multiresolution pyramid is used to locate the fiducials in the image using the templates. Thus, as indicated at 114, a search is made of the current image in low resolution for

6

candidate matches of all template families. In the exemplary embodiment of the invention, one-third resolution is used at this point. Matches are made using a normalized correlation between the template and the image. The matches found in low resolution are then verified and localized in high resolution at 115. The K best matches are then selected as the most reliable fiducials at 116 where K equals the number of fiducials to be tracked. The user is then given the opportunity at 117 to edit the detected location of fiducials found either through use of the idealized or pre-stored templates or templates generated interactively.

The details of the low resolution detection routine performed in block 114 of FIG. 7 is shown in FIG. 8. As shown at 114.1, the image can be raster scanned selecting points using sparse sampling. In raster scanning pixels are considered successively along each line, line-by-line in increments of one, while in sparse sampling the increment is greater than one. Alternatively, the image can be raster scanned as indicated at 114.2, selecting candidate points using interest operators followed by thresholding. Interest operators are simple patterns which emphasize gray scale characteristics of a particular fiducial. An example is shown in FIG. 17, where the fiducial is a light circle 73 on a dark background 75. The interest operator 77 could be, for instance, the one pixel value 79 in the center having a gray scale value matching that of the light circle 73, and the four pixels 81 at the cardinal points having gray scale values similar to that of the background 75. Such interest operators permit rapid searching of the image and should be selected as to assure identifying all of the fiducials in the family. They will most likely also generate additional candidate points. Returning to FIG. 8, the interest operator generated value in the exemplary system is the relative albedo. The relative albedo of each point in the low resolution scan is compared to a threshold value to select candidate points.

For each candidate point, a template matching is performed at 114.3, using a normalized correlation. Unwanted point matches are then filtered out at 114.4 using thresholding on the normalized correlation value. In the exemplary embodiment, a normalized correlation of 0.75 was used as the threshold. Bracketing and interpolation are then used at 114.5 to localize the remaining point/matches. In implementing bracketing, a rectangular image window is selected within which the desired point match will definitely lie. Then by interpolating between the correlation values of points on the border of the selected window along with its center, a new estimate of the location of the point match is calculated. This process is repeated with successively smaller windows centered on the new estimate of the location of the point match until a singular point is reached. In the exemplary system, the interpolation is performed using a two-dimensional Gaussian distribution.

FIG. 9 illustrates the techniques for verifying the candidate matches in high-resolution indicated at 115 in FIG. 7. Bracketing is performed on the selected matches in high resolution as indicated at 115.1. These points are then filtered at 115.2 within the same image neighborhood using minima suppression. In implementing minima suppression, for each point which has been a match, an area the size of the template is centered on the point. A point is selected as a further candidate match only if it is the best correlation with the template within the template window.

An important aspect of the invention is the fine tuning of the tracking templates called for at 120 in FIG. 6. FIG. 10 illustrates the details of fine tuning the templates. As indicated at 121, the median point/match from fiducials detected using the same initial template is selected. For example, if

there are three point matches for a fiducial family, the match having the middle value of correlation is selected. Notice that the match with the best correlation is not selected as it is likely to eliminate some valid matches. This technique adapts the selection of the template to be used for tracking to the actual conditions existing at the time of the selection. The relevant image portion is then acquired as the new template at 122, and the position, the interest operator value and the normalized correlation for all relevant point/matches using this newly acquired template is then recorded at 123. The steps 121-123 are accomplished for each template family. Then, the current special pattern of all the fiducials determined by the point/matches, is recorded at 124.

The program then enters the tracking loop at block 130 in FIG. 6. The routine for continuous tracking, which is called at 140 in FIG. 6 is illustrated in FIG. 11. The new position of the fiducial is estimated at 131 by projecting a velocity vector calculated from prior positions of the fiducial. Localization of fiducial position is then implemented in low resolution using bracketing and interpolation as indicated at 132. This is followed by high resolution localization of the fiducial position at 133, also using bracketing and interpolation.

The low resolution localization of block 131 is implemented by the routine illustrated in FIG. 12. As indicated at 132.1 points are selected by raster scanning the image window using sparse sampling. If interest operators are used, the interest operators with the value closest to that of the fiducial in the previous tracking step is selected at 132.2. In either case, a best match is selected using normalized correlation template matching at 132.3. This is followed by bracketing on the position of the best match at 132.4.

FIG. 13 illustrates the high resolution localization of fiducials called for in block 133 of FIG. 11. As indicated, bracketing is performed on a candidate with best match in high resolution as indicated at 133.1. If a match is found, the normalized correlation, interest operator value and position of the best match are calculated at 133.2. If desired, the sub-pixel accuracy of the position can be calculated at 133.3. The same interpolation technique as in bracketing and interpolation, as described above, is used. Alternatively, bilinear interpolation between the surrounding pixel correlation values could be used. Finally, if needed, charge coupled device (CCD) jitter is filtered out of the position at 133.4. In the exemplary system, a low pass filter is used.

The lost fiducial routine 150 in FIG. 6 is shown in FIG. 14. If the tracking routine finds no fiducial within the specified image window at 151, then clearly the fiducial has been lost. Even if a fiducial has been found, confirmation must be made that it is in fact the new position of the fiducial. Hence, a number of constancy tests are applied in 152. For instance, the normalized correlation value and the interest operator value must not change by more than a selected amount, such as, for example, 15%, from the most current values. Also, image limits are applied. For instance, the fiducial should not have changed position by more than a predetermined amount or, if the edge of the image is reached, the position indicated is not accepted as the fiducial may be out of the field of view, although a continued indication that it is at the edge may be presented.

The routine 180 in FIG. 6 for reacquiring the lost fiducial is shown in FIG. 15. First, the new position of the fiducial is estimated at 181 using a larger search window than was used at 141 in FIG. 11. The image window is then raster scanned in high resolution using sparse sampling to select the best match, if any, at 182. Bracketing is then performed

around the position of the best match, if any, at 183. The normalized correlation interest operator albedo and the position of the fiducial best matched is then determined at 184. This is followed by calculation of sub-pixel accuracy, if needed, at 185. Finally, the number of successive attempts to reacquire the fiducial is updated at 186.

FIG. 16 illustrates the routine 200 in FIG. 6 for generating the alarms and gating the accelerator or beam generator. The direction and distance traveled by each currently actively tracked fiducial since the detection step is estimated at 201. The special pattern of the actively tracked fiducials is compared with the initial pattern and previous patterns at 202. Any quasi-periodic motion associated with the individual fiducials and/or the special pattern is predicted at 203 such as by using past data analysis. This would include movement associated with breathing or tremor of the patient. The alarm warnings, alarm states and accelerator gating signals are then computed at 204 for display or for feedback to the equipment, such as the accelerator.

While specific embodiments of the invention have been described in detail, it will be appreciated by those skilled in the art that various modifications and alternatives to those details could be developed in light of the overall teachings of the disclosure. Accordingly, the particular arrangements disclosed are meant to be illustrative only and not limiting as to the scope of invention which is to be given the full breadth of the claims appended and any and all equivalents thereof.

What is claimed is:

1. Apparatus responsive to movement of a patient positioned on a patient positioning assembly during treatment/diagnosis, said apparatus comprising:

camera means generating digital image signals representing an image of at least one passive fiducial having a lambertian surface on said patient; and

processing means comprising means responsive to actual shape, appearance and lighting conditions of said at least one passive fiducial having a lambertian surface in said image represented by said digital image signals to determine successive positions of said at least one passive fiducial having a lambertian surface, means repetitively determining movement of said at least one passive fiducial having a lambertian surface from said successive positions, and means generating an output in response to predetermined values of said movement.

2. Apparatus responsive to movement of a patient positioned on a patient positioning assembly during treatment/diagnosis, said apparatus comprising:

a single camera generating digital image signals representing an image of at least one fiducial on said patient; and

processing means comprising means responsive to actual shape, appearance and lighting conditions of said at least one fiducial in said image represented by said digital image signals to determine successive positions of said at least one fiducial, means tracking three-dimensional movement of said at least one fiducial from said successive positions and means generating an output in response to predetermined values of said movement.

3. The apparatus of claim 2, wherein said means repetitively determining movement of said at least one fiducial includes means detecting movement associated with patient breathing, and said output means comprises means generating a gating signal synchronized to said patient breathing.

4. The apparatus of claim 2, wherein said processing means comprises means repetitively applying multiple lev-

els of filtering to said digital image signals to determine successive positions of said at least one fiducial.

5. The apparatus of claim 4, wherein said means applying multiple levels of filtering includes means applying bracketing and interpolation to said digital image signals to determine position of said at least one fiducial.

6. The apparatus of claim 4, wherein said means applying multiple levels of filtering includes means applying minima suppression to said digital image signals.

7. The apparatus of claim 4, wherein said means applying multiple levels of filtering include means applying at least two types of filtering selected from a group consisting of correlation, sparse sampling, bracketing and interpolation, and minima suppression.

8. The apparatus of claim 7, wherein said processing means includes means using multiple levels of resolution of said digital image signals to determine successive positions of at least one fiducial and said means applying multiple levels of filtering comprise means applying filtering at each of said multiple levels of resolution.

9. The apparatus of claim 4, wherein said processing means includes means using at least one of templates and interest operators to determine successive positions of said at least one fiducial from said digital image signals.

10. The apparatus of claim 2, wherein said pressing means comprises means using a template to successively determine position of said at least one fiducial and means selecting said template.

11. The apparatus of claim 10, wherein said at least one fiducial comprises a plurality of fiducials, and said means selecting a template includes means generating an initial template, means generating template matches for each of said plurality of fiducials from said digital image signals using said initial template, and means selecting one of said template matches for use in determining positions of each of said plurality of fiducials.

12. The apparatus of claim 11, wherein said means selecting said one of said template matches includes means generating a value for each of said templates matches, and means selecting a template match having a median value as said one template match.

13. Apparatus responsive to movement of a patient positioned on a patient positioning assembly during treatment/diagnosis, said apparatus comprising:

camera means generating digital image signals representing an image of at least one fiducial on said patient; and processing means comprising means responsive to actual shape, appearance and lighting conditions of said at least one fiducial in said image represented by said digital image signals to determine successive positions of said at least one fiducial at a rate of at least 20 Hz, means tracking movement of said at least one fiducial from said successive positions, and means generating an output in response to predetermined values of said movement.

14. The apparatus of claim 13, wherein said means generating an output includes means generating an indication of movement relative to at least one selected level of displacement.

15. The apparatus of claim 14, wherein said means generating said indication of movement includes means providing a warning that said movement exceeds a first displacement and means providing a signal for terminating

radiation treatment/diagnosis when said movement exceeds a second displacement greater than said first displacement.

16. The apparatus of claim 14, wherein said means generating an indication of movement comprises display means generating an image of said fiducials and an indication of said movement relative to said first and second displacements.

17. The apparatus of claim 16, wherein said camera means includes means generating digital image signals for a plurality of fiducials, said means repetitively determining movement determines movement of each of said plurality of fiducials, and said display means includes indicator means indicating a fiducial with the greatest movement.

18. The apparatus of claim 14, wherein said means repetitively determining movement includes means detecting movement associated with patient breathing and random movement, and wherein said means generating an indication of movement indicates said random movement.

19. Apparatus responsive to movement of a patient positioned on a patient positioning assembly during treatment/diagnosis, said apparatus comprising:

camera means generating digital image signals representing an image of at least one fiducial on said patient; and processing means comprising means responsive to actual shape, appearance and lighting conditions of said at least one fiducial in said image represented by said digital image signals to determine successive positions of said at least one fiducial, means repetitively determining movement of said at least one fiducial from said successive positions, and means generating an output in response to predetermined values of said movement;

said processing means further comprising means using a template to successively determine position of said at least one fiducial and means selecting said template comprising display means, means generating on said display means an image of said at least one fiducial from said digital image signals and user interface means for selection of a template from said image of said at least one fiducial.

20. Apparatus responsive to movement of a patient positioned on a patient positioning assembly, said apparatus comprising:

camera means generating digital image signals representative of an image of said patient; and

processing means comprising means determining movement of said patient from said digital image signals, including movement associated with breathing by said patient, and gating means generating gating signals synchronized with said movement associated with breathing by said patient.

21. The apparatus of claim 20, wherein said camera means generates said digital image signals representing an image of at least one fiducial on said patient, and said means determining movement of said patient includes means determining movement of said at least one fiducial.

22. The apparatus of claim 20 adapted for use during treatment of said patient with a radiation beam generated by a beam generator, wherein said gating means comprises means generating said gating signals synchronized to actuate said beam generator in synchronism with patient breathing.